

Tethered Power Systems for 1 kW-Class Landers and Rovers

Ara Kourchians | ara.kourchians@jpl.nasa.gov

Ansel Barchowsky

[Abigail Guicheteau](#)

Clara MacFarland

Coleman Richdale

Molly Shelton

[Nicole Stokowski](#)

Malcolm Wright

Travis Brown

Ashot Hambarzumyan

Stephen Manion

Blake Shaffer

Celeste Smith

Rachel Tsao

Summer Yang

Matthew Caballero

Curtis Jin

Garlen Mousesian

Justin Schachter

Russell Smith

Carlos Villalpando

Affiliation: Jet Propulsion Laboratory, California Institute of Technology

Affiliation: University of Illinois Urbana-Champaign

Copyright © 2025 by California Institute of Technology. Government sponsorship acknowledged
This information has been reviewed and approved for public distribution.



Jet Propulsion Laboratory
California Institute of Technology

CLPS-Class Tethered Power Systems

Motivation

Connecting nuclear and solar power generation to remote payloads is essential for a sustained human and robotic presence on the Moon, Mars, and beyond

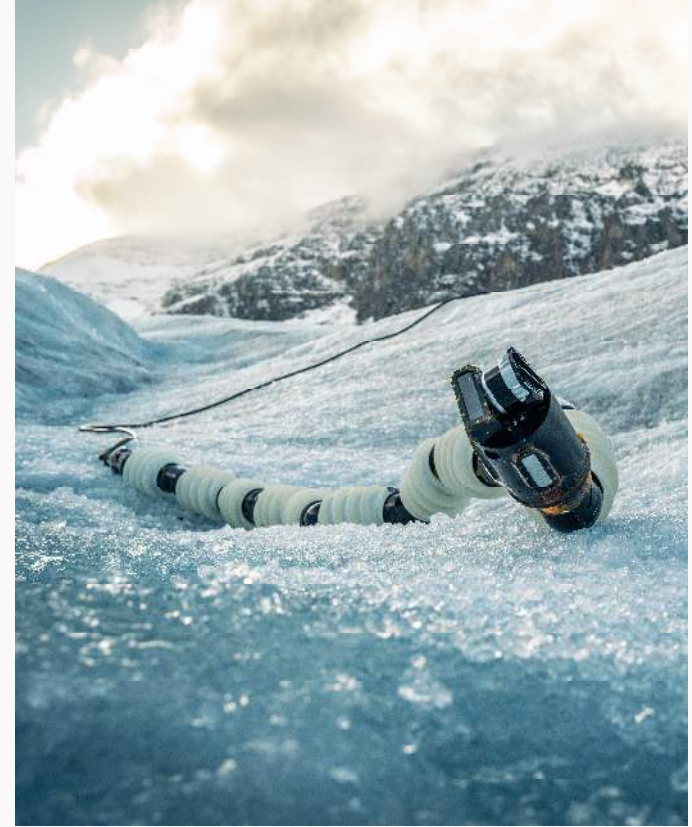
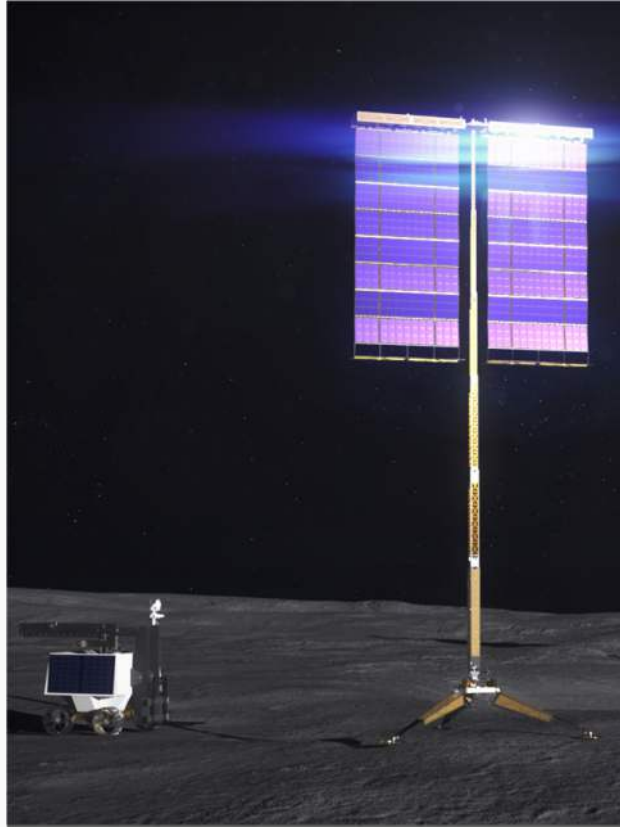

CLPS-Class Tethered Power Systems

Enabling CLPS-Scale Tethered Rovers

NASA and its partners are producing CLPS-scale rovers for Lunar exploration. TULIPS can provide power and communications as a service to those rovers, enabling exploration of the most extreme terrain on the Moon.



Power Delivery

1 kW, 1.5 kV



Fiber Ethernet

1 Gb/s



Tether & Tether Deployment

1 km, bi-directional



A



B



C



D

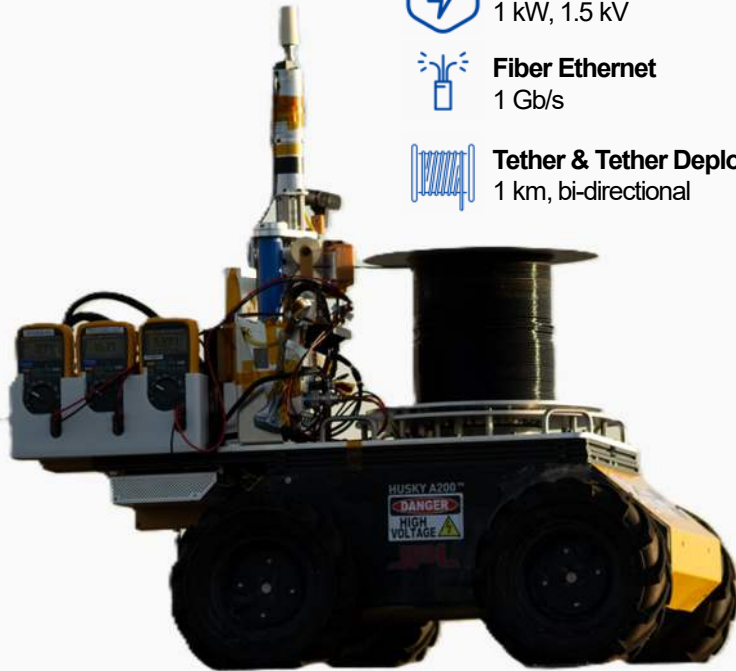

System Architecture

TULIPS is a complete tethered power and communications system, using medium voltage DC to efficiently transmit power on ultralight cables

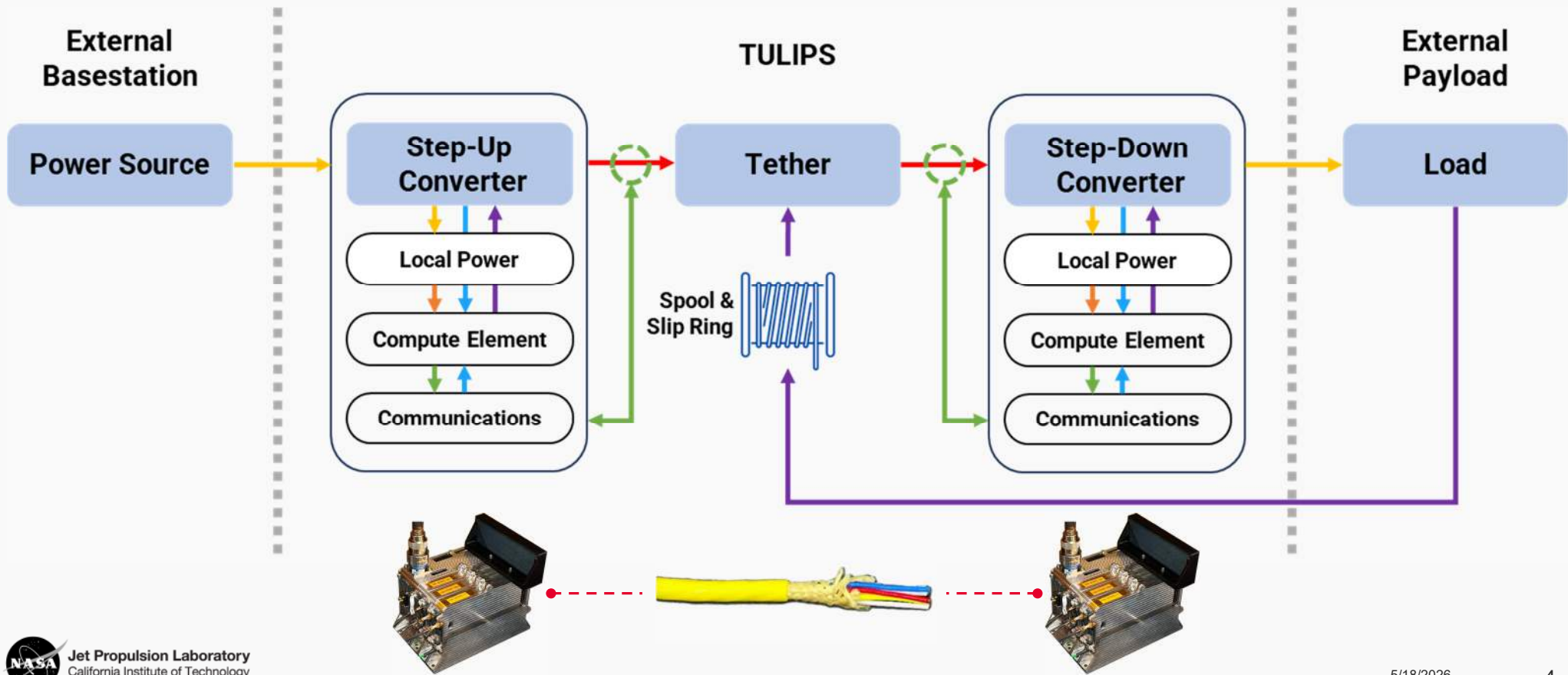

DC Power Transmission

- Stacked LLC power converters enable medium-voltage DC (MVDC) transmission
- The MVDC tether transmission voltage is divided between the converters, reducing voltage stress

Power Stage Specific Power

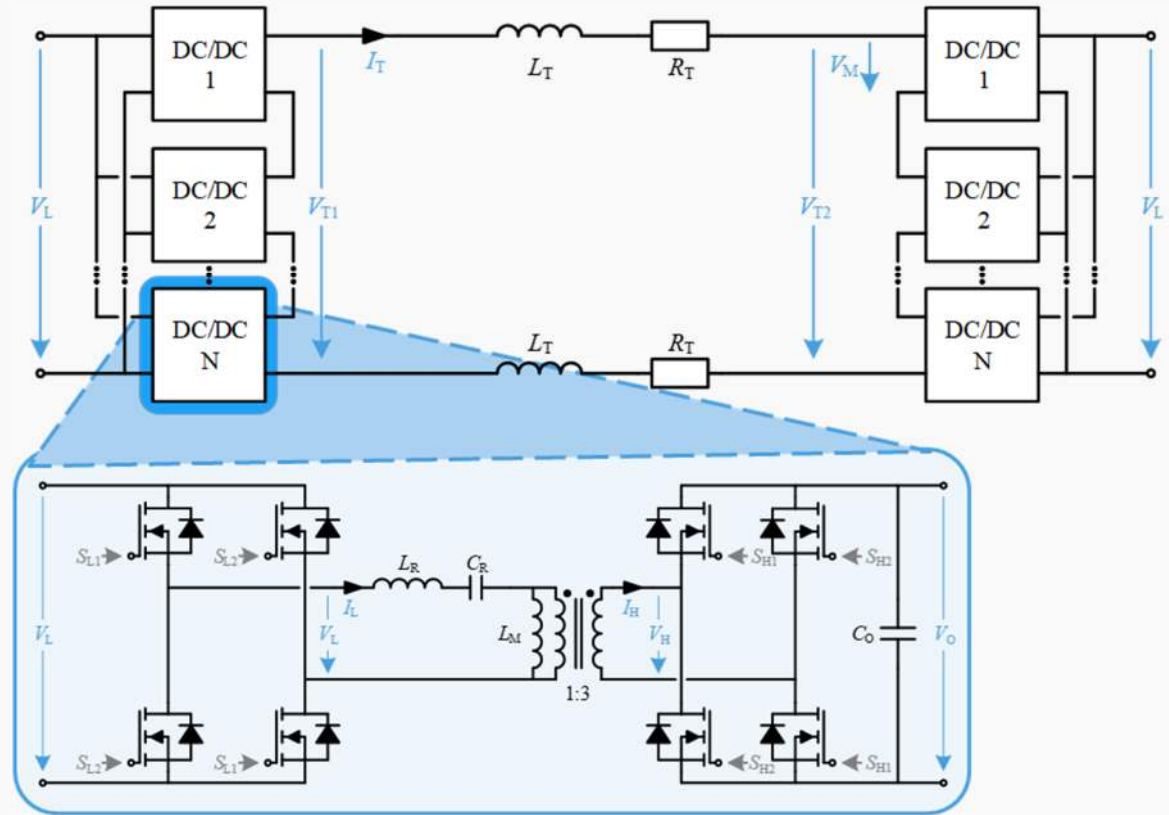
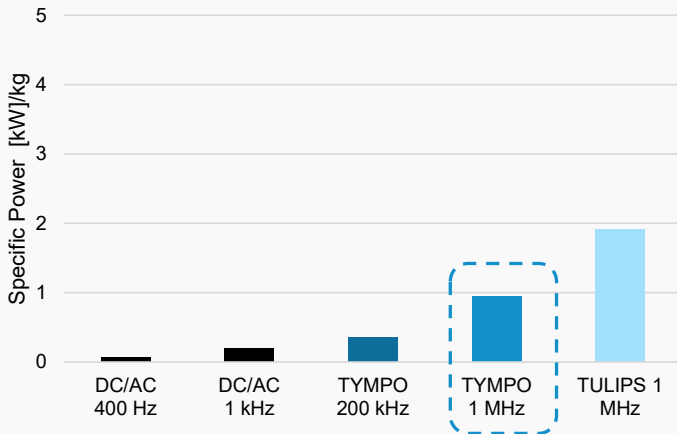

Modular Power Conversion

- Stacked LLC power converters enable medium-voltage DC (MVDC) transmission
- The MVDC tether transmission voltage is divided between the converters, reducing voltage stress
- Automotive GaN FETs are used to achieve high efficiency (97.5%) and specific power (1 kW/kg)

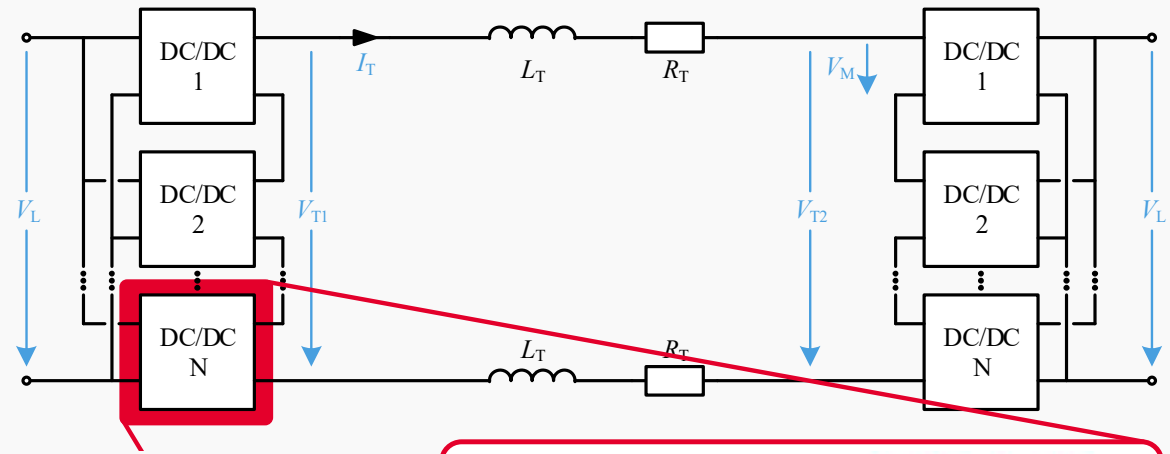

Parameter	Specification
• System Power	1 kW
• Module Power	0.3 kW
• Input Voltage	100 – 120 V
• Tether Voltage	1.5 kV
• Efficiency	97.5 %
• Specific Power	0.95 kW/kg

Converter Efficiency from 100 V to 900 V

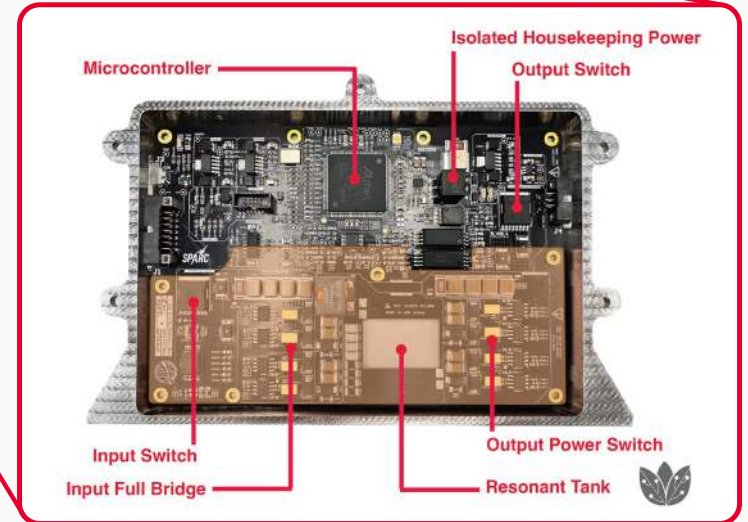

Communications

- **1 Gb/s fiber ethernet** – A modified COTs transceiver provides a 2.5 Gb/s singlemode fiber link over radiation-hardened fiber optic
- **Standard interface** – Customer sees a standard ethernet link
- **Telemetry and commanding** – Seamlessly linked on optical link
- **Demonstrated** up to 40 km with bit error rate less than 1×10^{-9}
- Verified by streaming **cat videos**

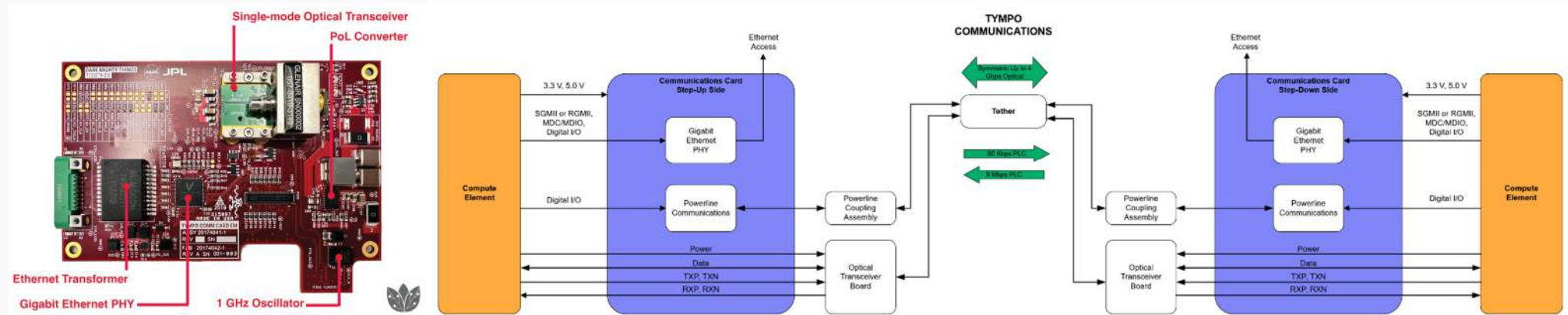
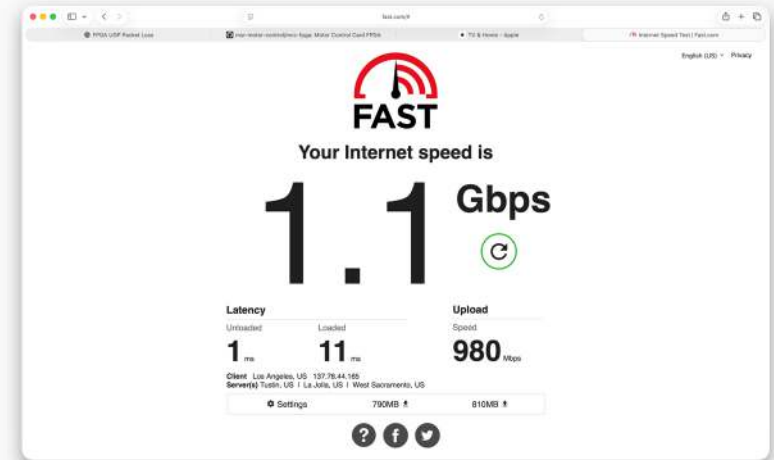

Lunar Tether Design, Fabrication, & Environmental Test

TetherCAD (<https://github.com/nasa-jpl/TetherCAD>) designs Lunar-rated cables using off-the-shelf vendor components, hardened to the extremes of the Moon

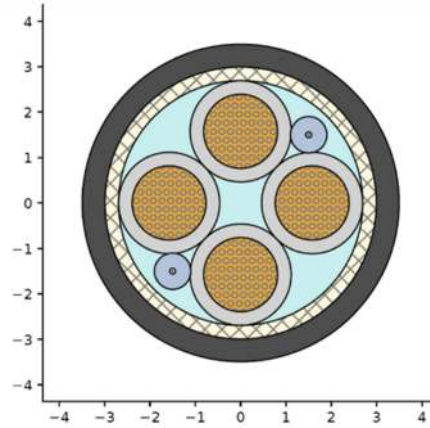
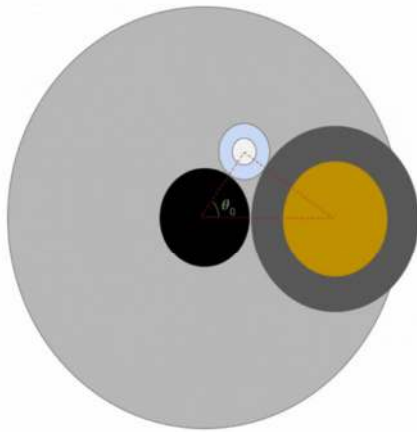

- **Core material:** A central structure for helical winding
- **Space-rated wire:** For power transmission and powerline communications
- **Radiation-hardened, single-mode fiber:** For high-speed communications
- **Aramid or Kevlar fiber:** Braided around the wire and fiber for strain relief
- **Extruded polymer jacket:** To provide abrasion resistance and hold the tether together

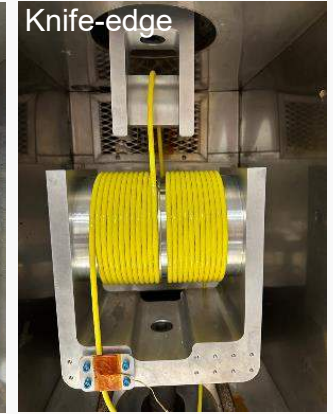
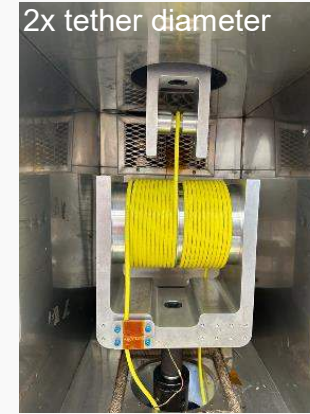

Strain testing of tether in Lunar thermal environment



Abrasion testing of tether in Lunar thermal environment

Tether Management Systems

JPL has developed TMS systems for a swath of rovers. To enable CLPS-class systems, this TMS is designed to be agnostic to the mobility system. It provides cable laying and respooling for rovers on the Moon or Mars

- **Tension sensor** – constant output tension
- **Friction Brake** – immune to kickback
- **Level winder** – compact respooling
- **Spool** – stores 1 km of tether

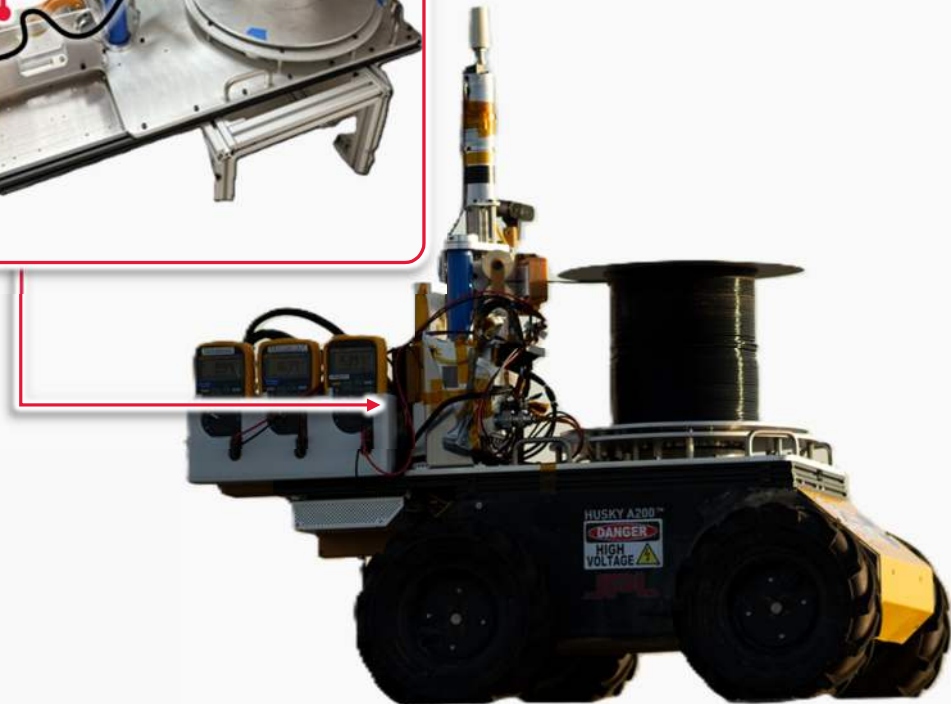
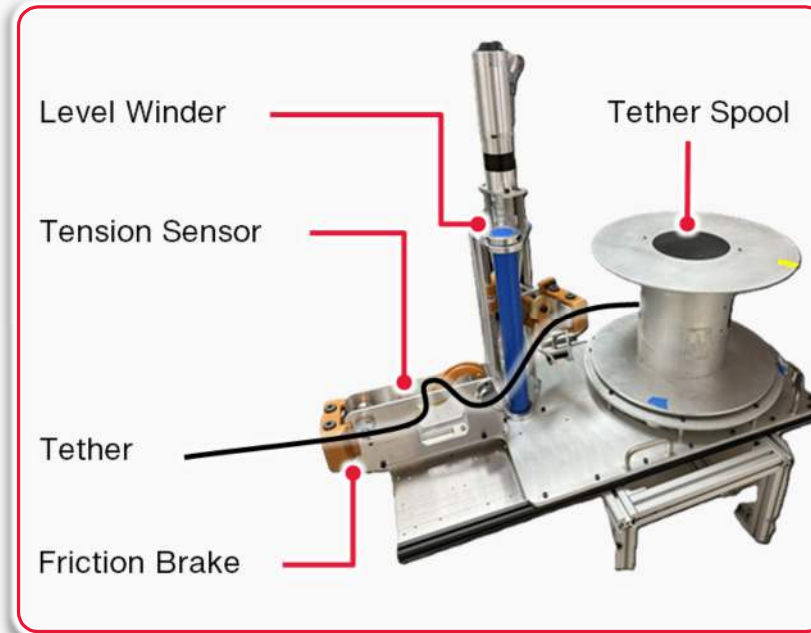

System Demonstration



We demonstrated the system in a 1 km drive on the JPL Mesa



The rover was **powered** by TYMPO, at 1 kW, 1 kV, enabling continuous driving and exploration



The rover drove **forward for 1 km, deploying** the tether
The rover drove **backward for 1 km, re-spooling** the tether

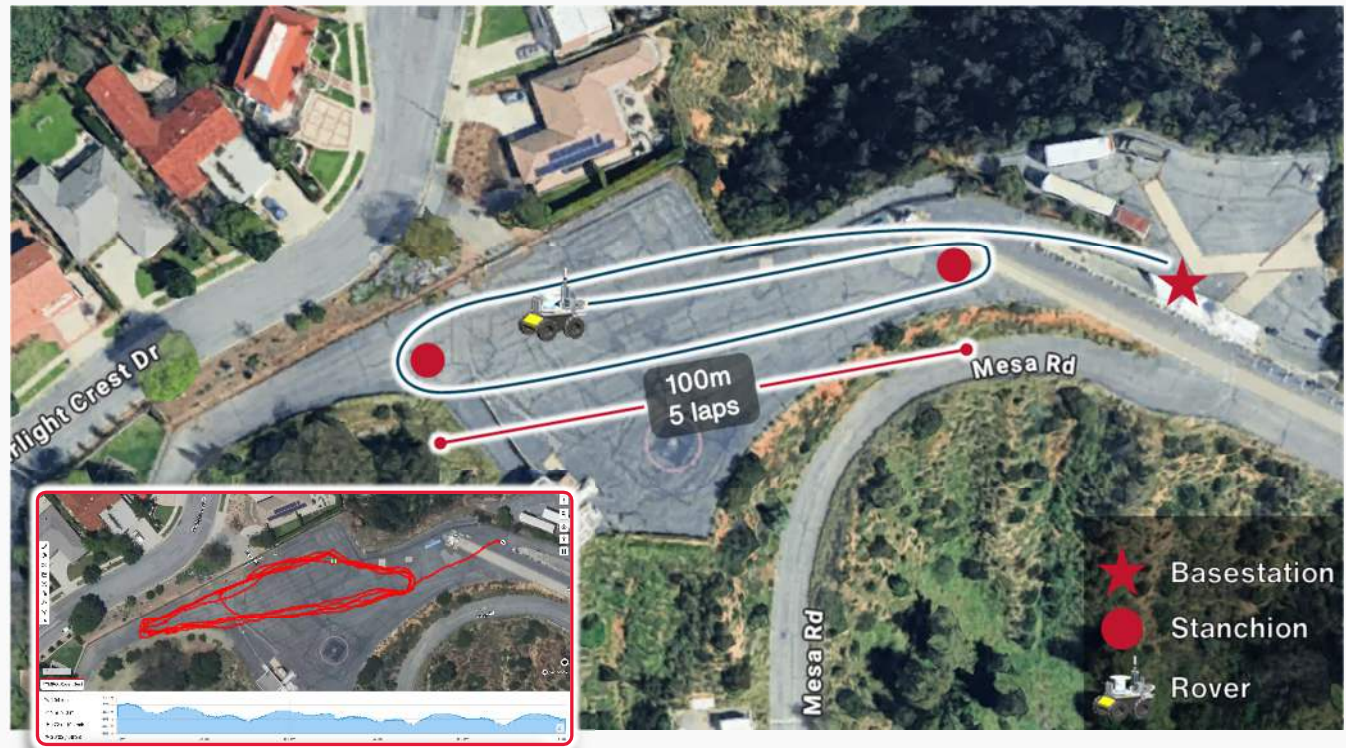

This information has been reviewed and approved for public distribution.

5/18/2026

CLPS-Class Tethered Power Systems



CLPS-Class Tethered Power Systems



Let's go to the Moon together!

To work together, reach out to us! We're here to support NASA and industry in building the future of spaceflight:

Ara Kourchians | ara.kourchians@jpl.nasa.gov

This information has been reviewed and approved for public distribution.



Jet Propulsion Laboratory
California Institute of Technology