

High-Reliability Uninterruptible Power Supply

Brandon Wang | Jet Propulsion Laboratory, California Institute of
Technology

Jet Propulsion Laboratory, California Institute of
Technology

Approved for Public Release
Does Not Contain CUI.



Jet Propulsion Laboratory
California Institute of Technology

High Reliability Power Supply

Agenda

- 1** Background
- 2** Block Diagrams
- 3** Results
- 4** Future Work

Does Not Contain CUI.

Background

- Implementing standard interfaces can significantly reduce design NRE
- Fault protection and uninterruptible power is key for critical mission events

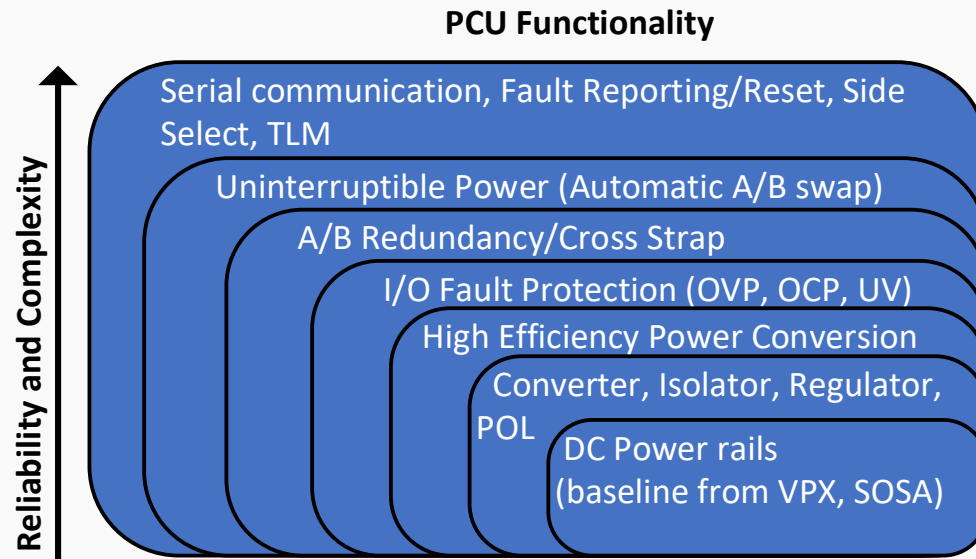

Block Diagram

Key Features

- Uninterruptible 12V and 5V outputs (referred to as golden node)
- A/B redundant converters and protection switches
- Fault protection logic to arbitrate which side is enabled to the output
- 6U form-factor with VITA78/SOSA interfaces

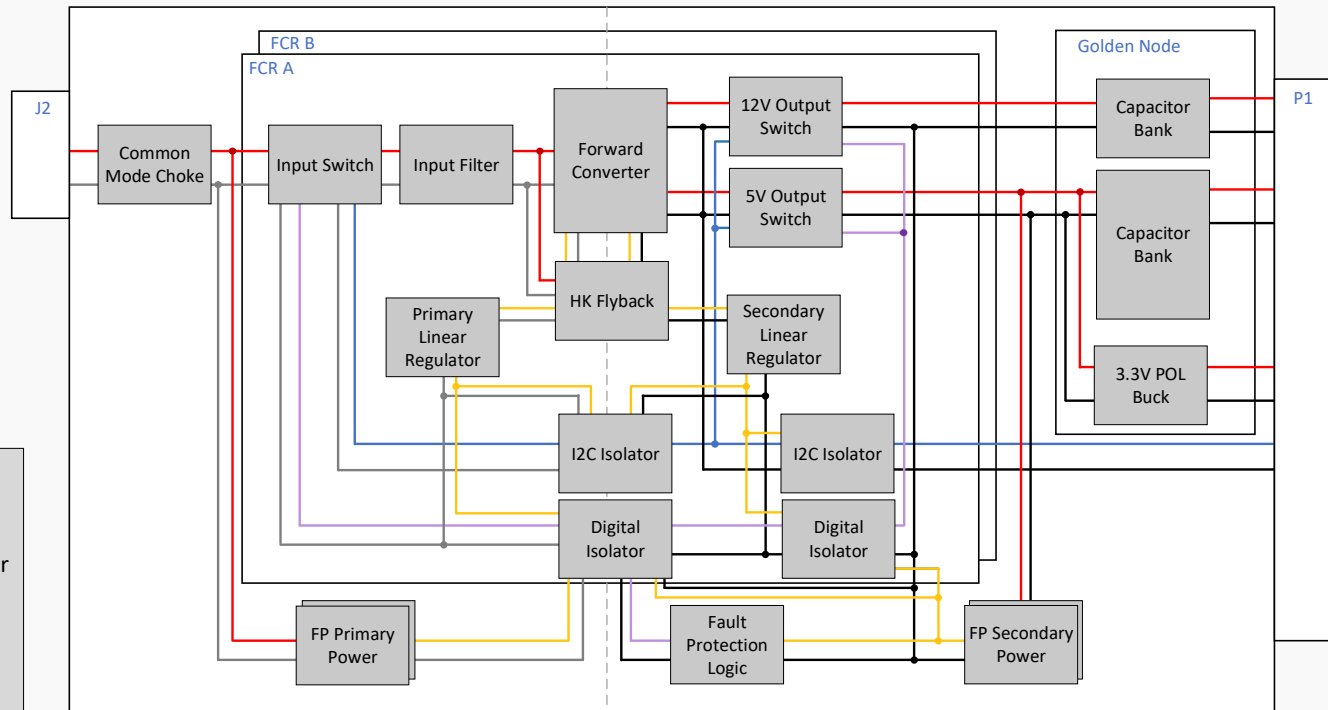
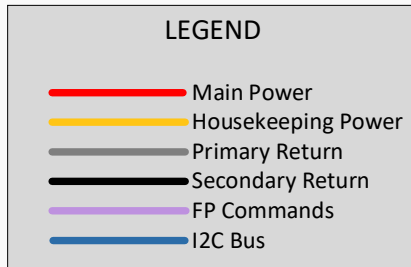

Fault Protection Behavioral Overview

- Enable both A and B sides to ensure golden node voltage is up
- Select which A/B side is enabled using external side-select signals
- Observe converter health using input and output protection switches' voltage and current telemetry
- Autonomously swap sides if fault been observed
- Latch "fault detected" bits to prevent swapping to a faulted side
- Use external reset signals to clear if any faults were previously detected on a side

Fault Protection Flow Diagram – Initial power-on

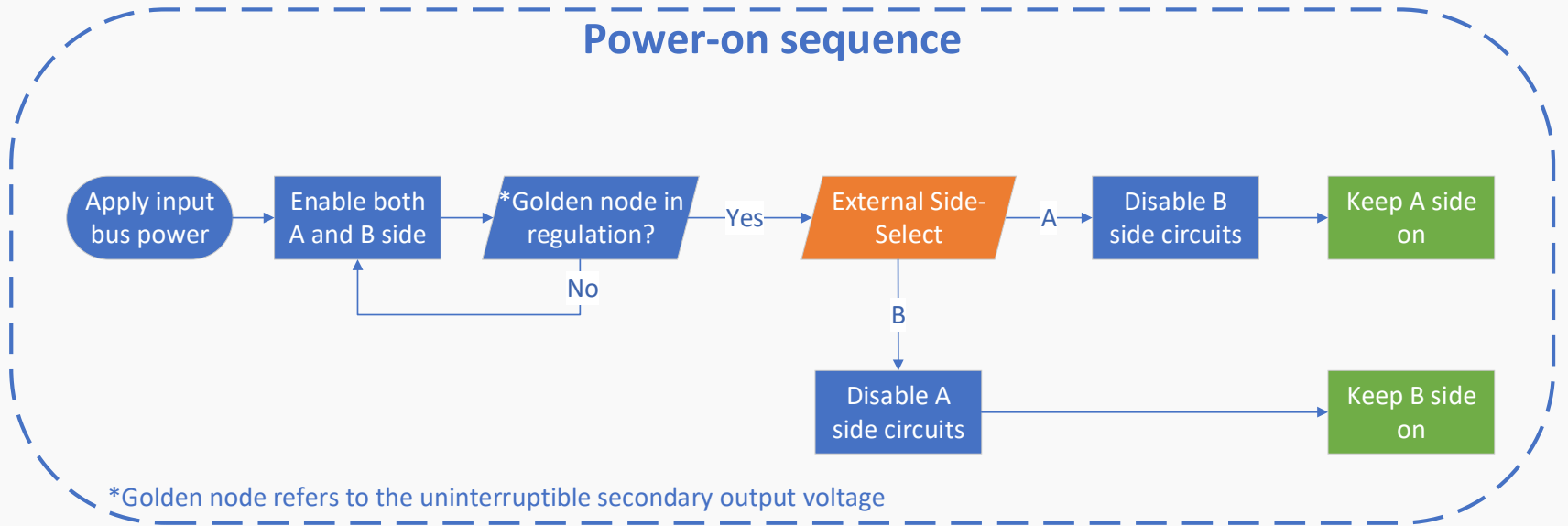
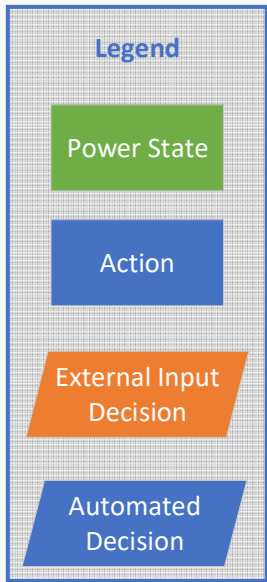

Fault Protection Flow Diagram – side selection

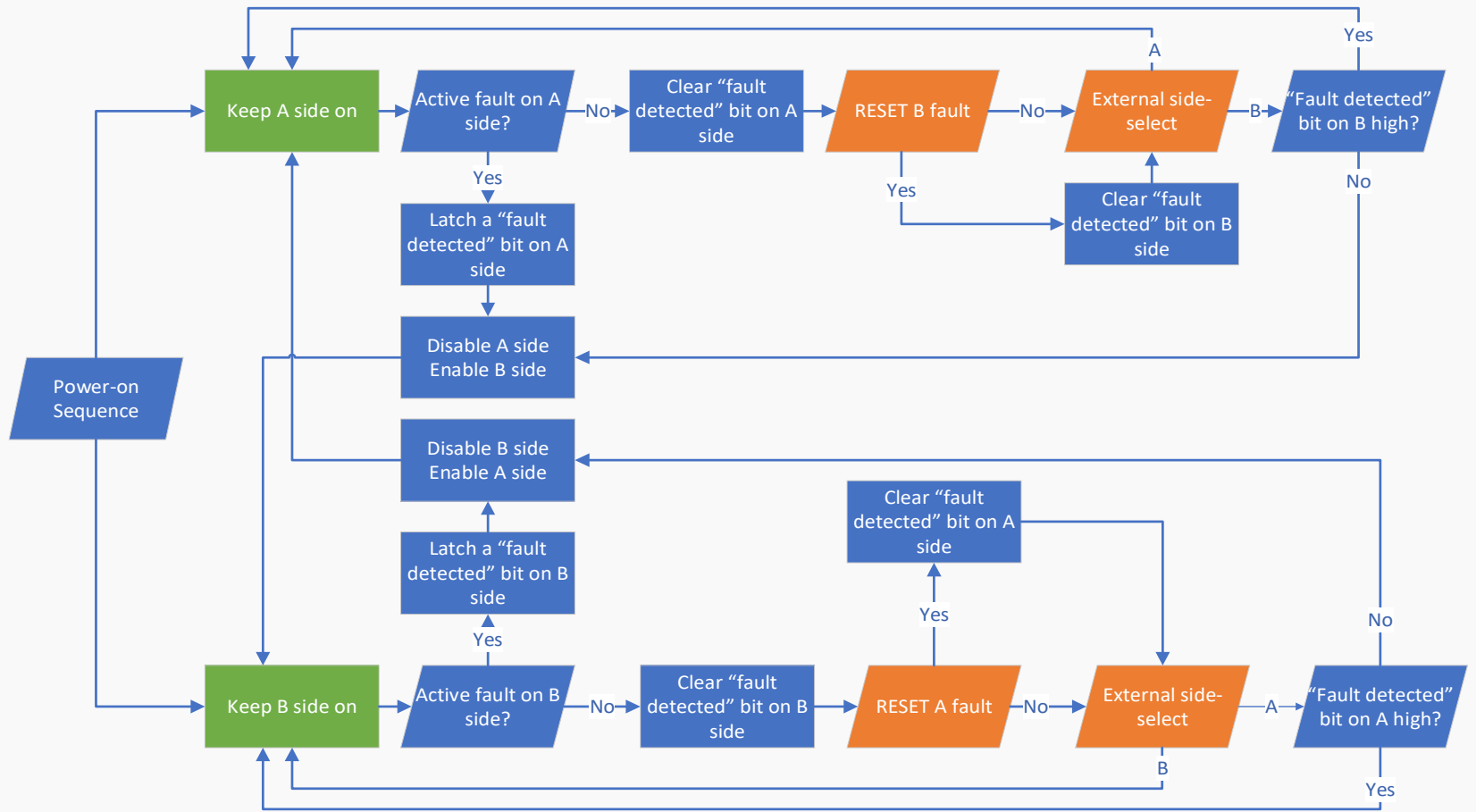
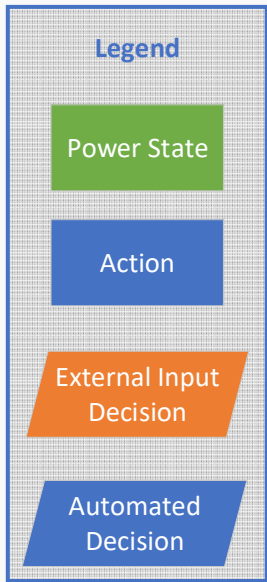

Sim results

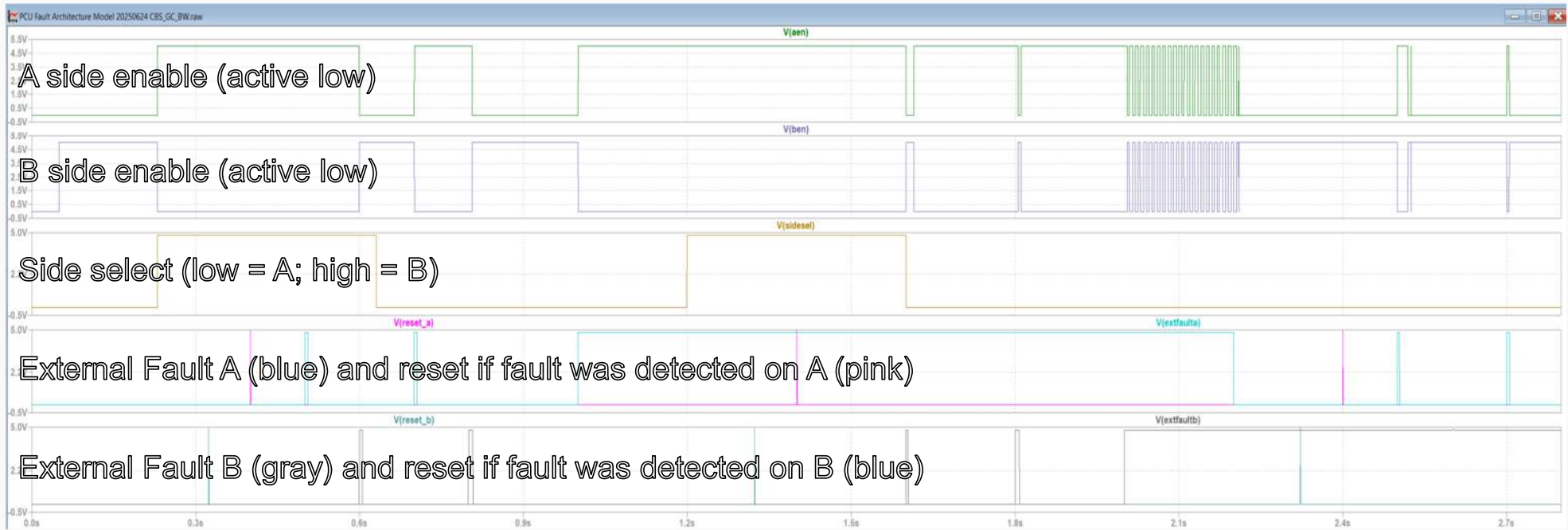

A side enable (active low)

B side enable (active low)

Side select (low = A; high = B)

External Fault A (blue) and reset if fault was detected on A (pink)

External Fault B (gray) and reset if fault was detected on B (blue)

Sim results

Side select chooses B side, so enable swaps

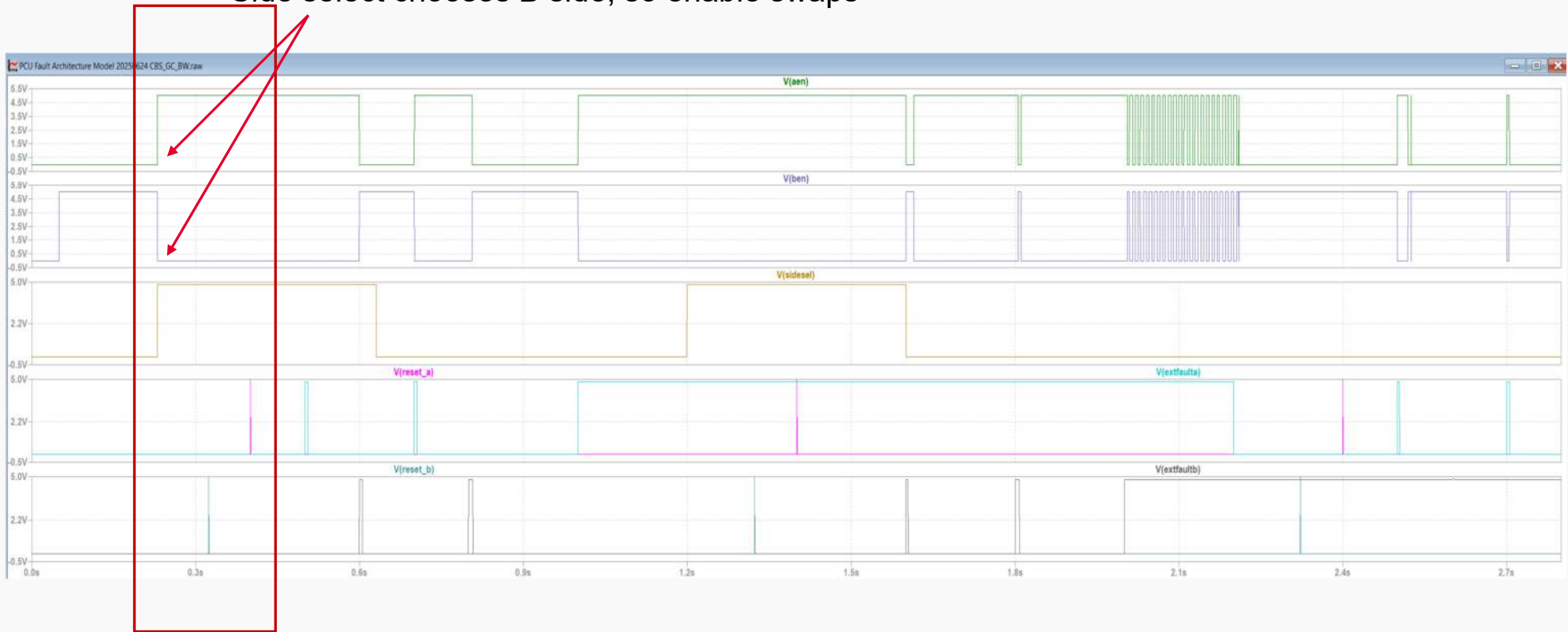

Sim results

Fault injected on B side, so change to A-side and ignore side select

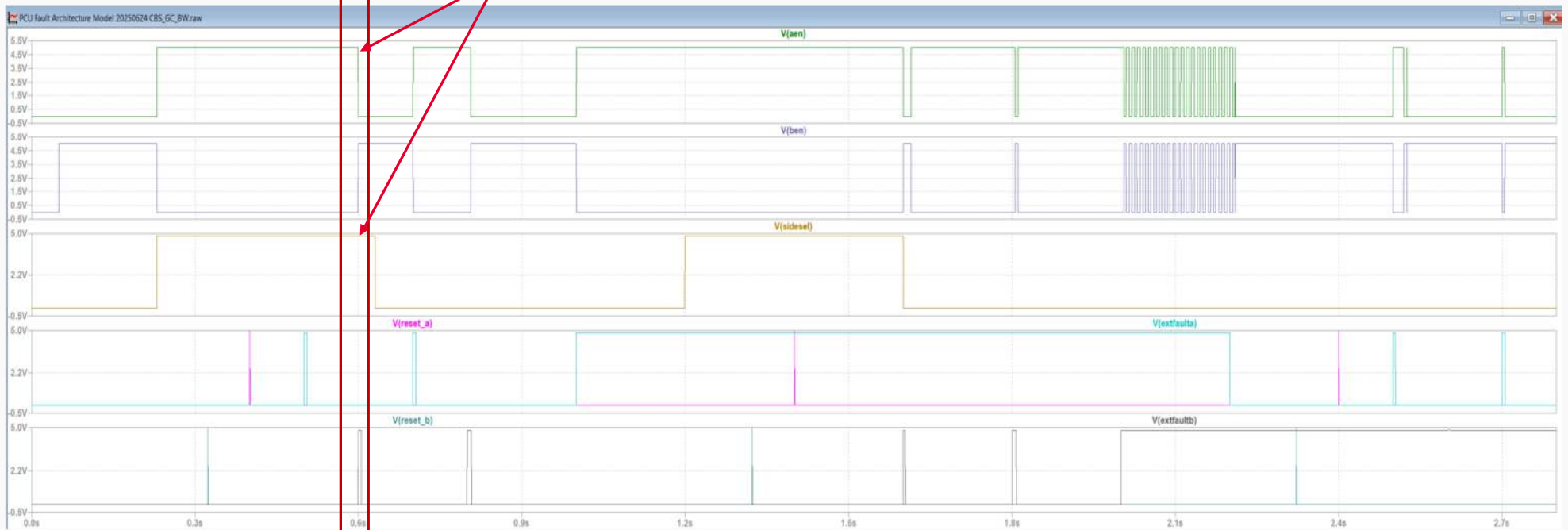

Sim results

Side select changed from A to B while already on B due to fault. No enable behavior change

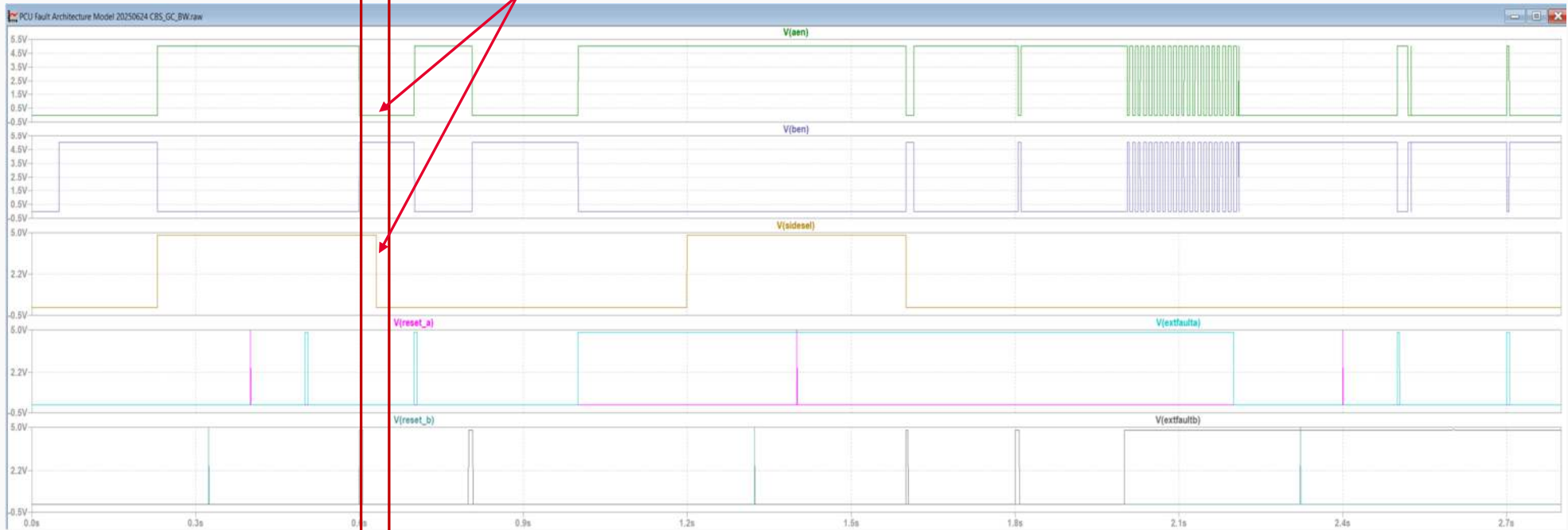

Sim results

Transient fault on B side while A side has a continued fault. Swaps to A side, then B side and stays on B since fault was cleared

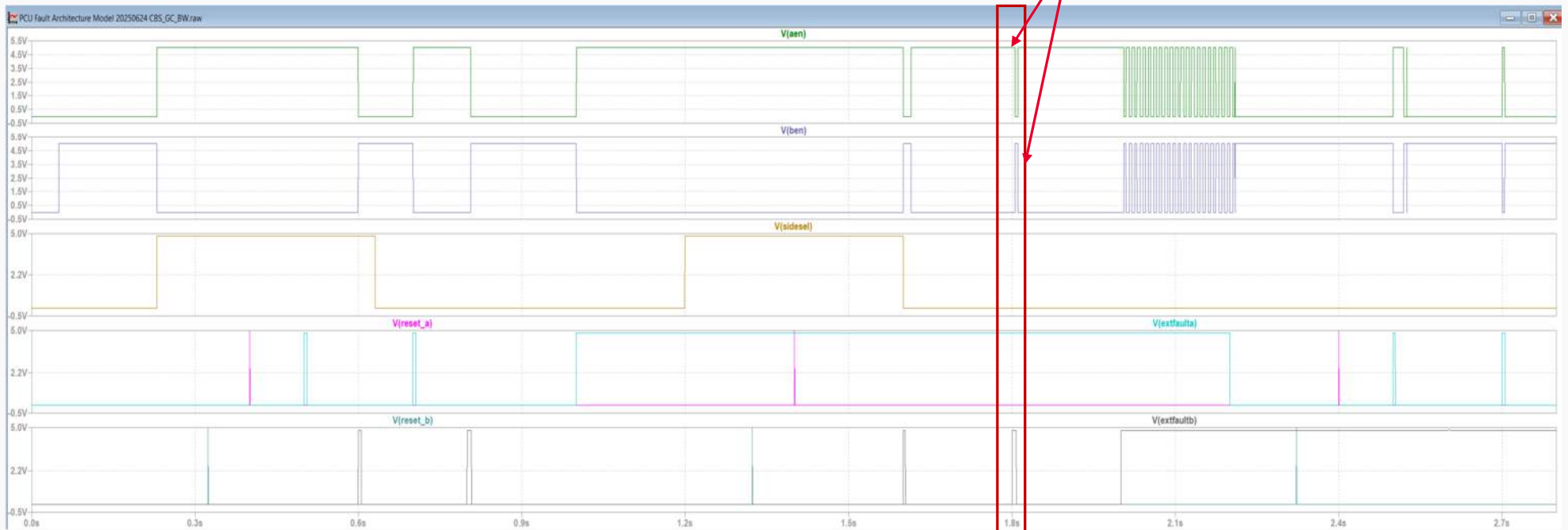

Sim results

Persistent fault on both sides. Persistent side toggling until A side fault is removed

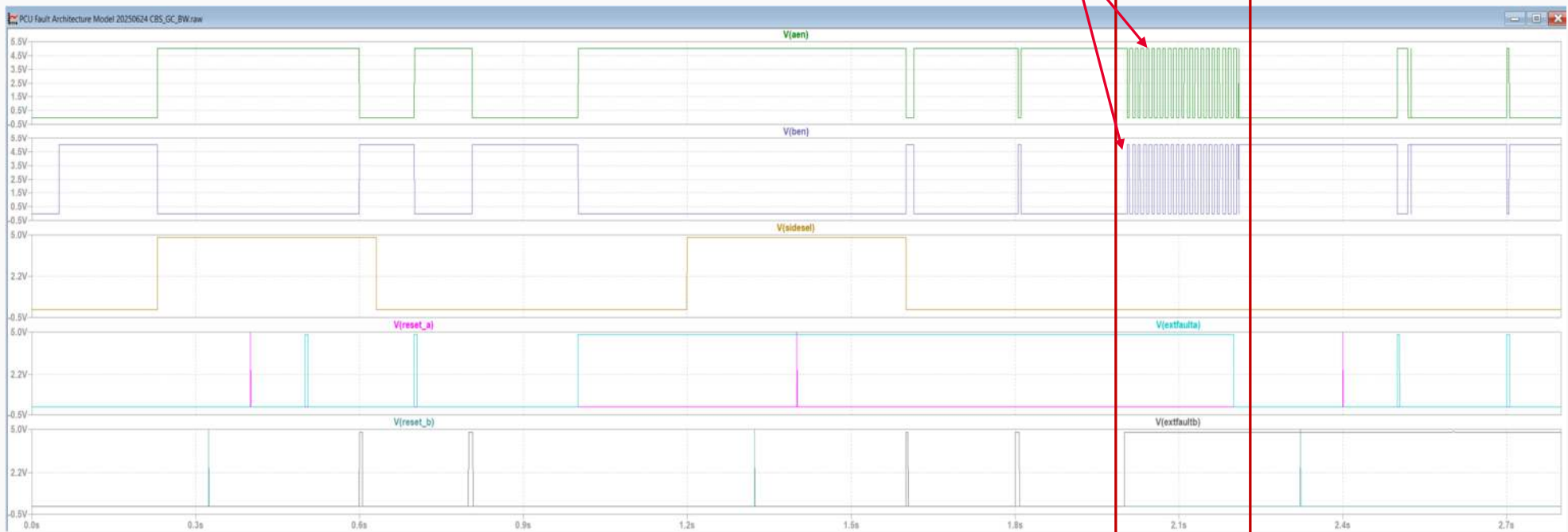

Hardware Photos

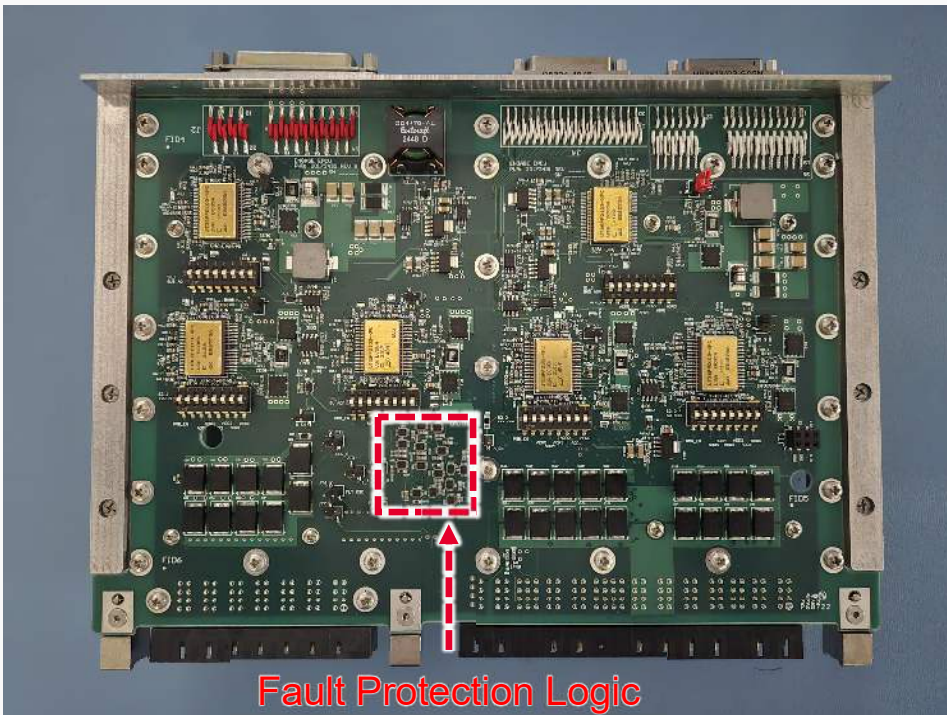

Power Converter Card

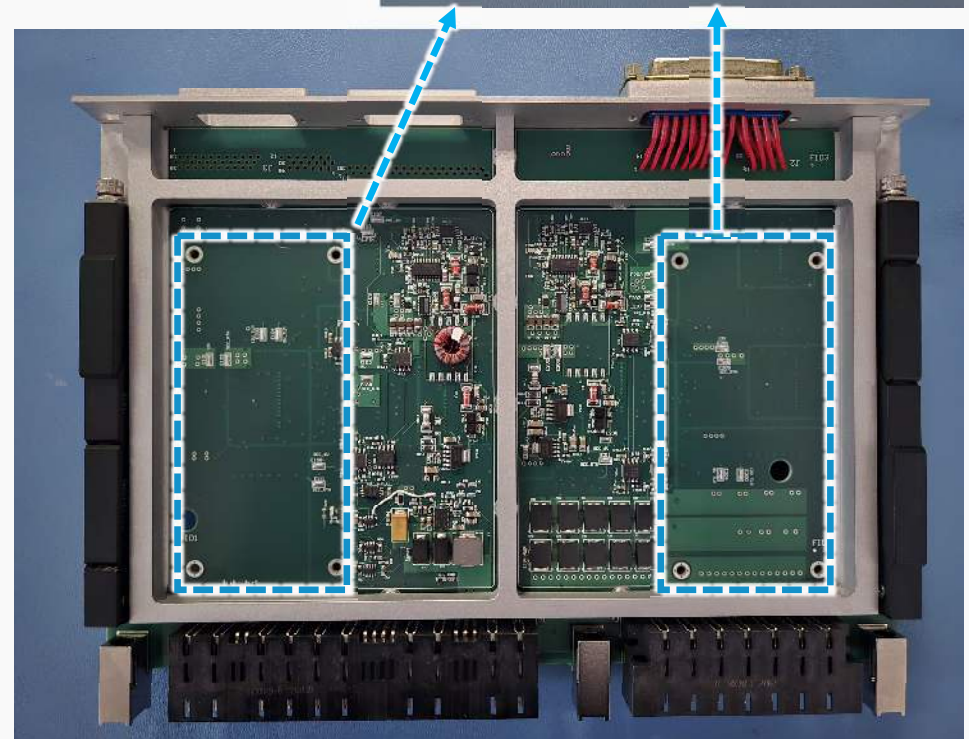

Test Results: Warm Spare vs Cold Spare

- Side swapping at 1A loads on both 12V and 5V output (17W total)
- Warm spare result – negligible change in output voltage
- Cold spare result – output voltage drops before recovering

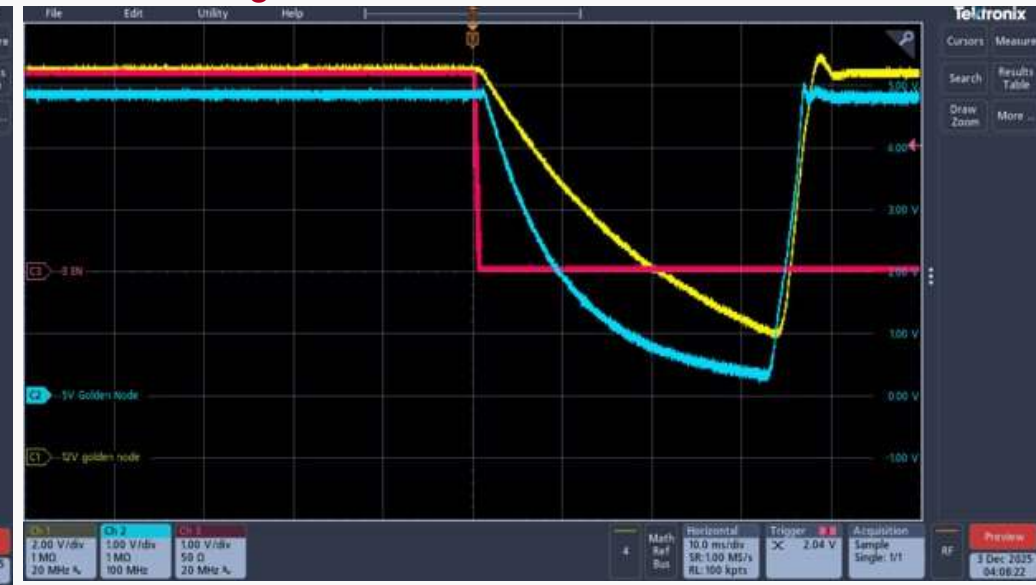
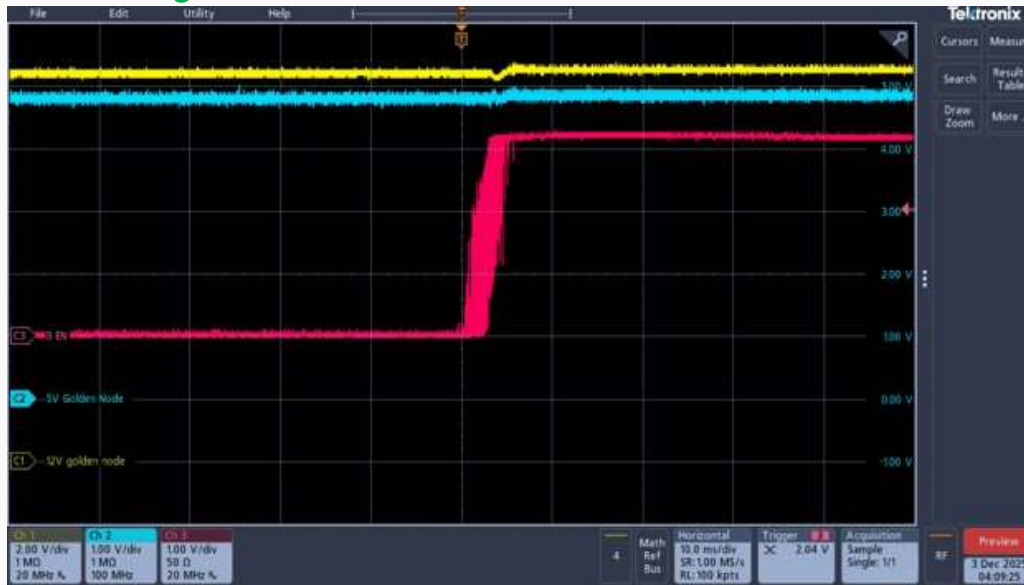

Future Work

- Update timing to allow for uninterrupted output during cold-spare operation
- Update fault protection circuitry TMR digital logic parts
- Tune converter design and performance

Special thanks to the PCU team!

Louis Freitas

Chase Christensen

Branden Kahn

Roxanne Arellano

Omid Sahebekhtiari

Chris Stell

Greg Carr

