



**RELIABLE SPACE POWER**  
***BRIDGING LEGACY DESIGNS WITH***  
***INNOVATIVE AND FLEXIBLE***  
***SOLUTIONS***

APRIL 22, 2026  
ABIGAIL EBERTS

STRATEGIC & TECHNICAL PRODUCT MARKETING  
RENESAS ELECTRONICS AMERICA INC.  
INTERSIL HIREL PRODUCT LINE

**intersil™**

# POWERING SPACE

intersil™

- Commitment to developing innovative IC for the Space and Strategic Programs
- Focused on high performance power, analog, mixed signal, and RF solutions
- 60+ years of flight heritage with rare product obsolescence
- Thorough radiation characterization, detailed reports, and RLAT
- Offer various flows to support cost effective fulfillment of a broad spectrum of mission requirements
- Solution-oriented designs to simplify customer implementation



# NON-NEGOTIABLES FOR SPACE POWER

intersil™



## Efficient

Thermal limitations drive efficiency requirements, requiring more power with higher efficiency



## Reliable

Consistent, reliable performance under a wide array of conditions is needed in the space environment



## Flexible

Software-defined payloads and short design cycles demand higher flexibility from power management solutions

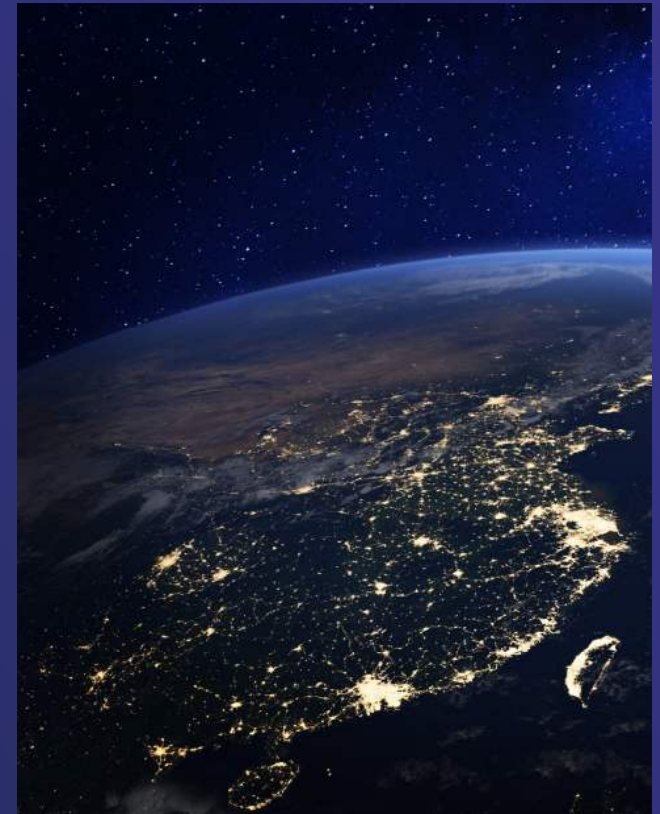

# ISL73846

## HIGHLY CONFIGURABLE FOR ISOLATED POWER



### Independent supplies and UVLO for chip & driver output stage

- Wide 4.5V to 20V range capable of driving MOSFETs or GaN FETs directly

### Select the control methodology

- Supports both current and voltage mode control

### Select the maximum duty cycle

- 50% Out of Phase or 100% IN or OUT Phase

### Internal 8MHz GBWP Error Amplifier

- Includes bypass configuration to utilize external Error Amplifier

### Supports a wide 20kHz to 2MHz $f_{sw}$ range

- Option to synchronize to an external clock

### Choose between three options for OC response

- Cycle-by-Cycle Current Limit, Hiccup, Ignore

### Features synchronous rectification for improved efficiency

- Includes split deadtime control

### Low power startup current for offline power supplies

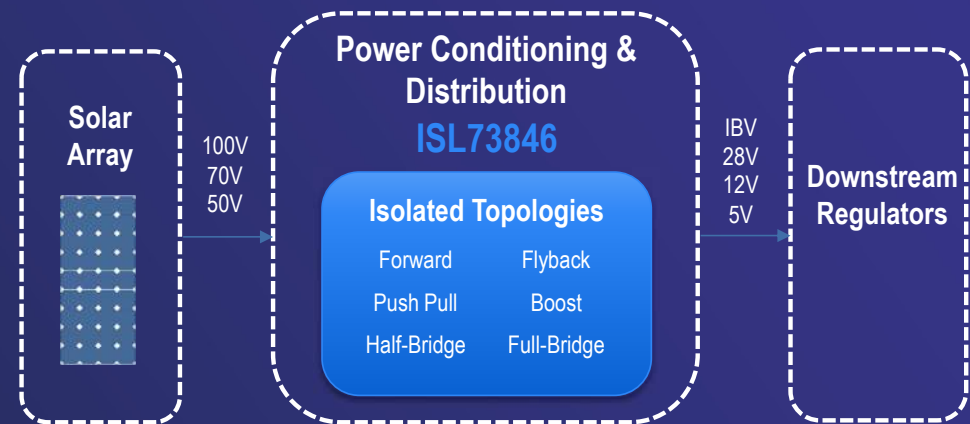

Flow	Part Number	TID LDR RLAT	SEE	Package
Rad Hard Hermetic	ISL73846SLHMF	75 krad(Si)	86 MeV·cm <sup>2</sup> /mg	24 Ld CFP
Rad Hard Plastic	ISL73846SLHMNEZ	75 krad(Si)	86 MeV·cm <sup>2</sup> /mg	64 Ld TQFP
Rad Tolerant Plastic	ISL73846M30/50NEZ	30/50 krad(Si)	46 MeV·cm <sup>2</sup> /mg	

# ISL73846

## HIGHLY CONFIGURABLE FOR ISOLATED POWER

### Independent supplies and UVLO for chip & driver output stage

- Wide 4.5V to 20V range capable of driving MOSFETs or GaN FETs directly

### Select the control methodology

- Supports both current and voltage mode control

### Select the maximum duty cycle

- 50% Out of Phase or 100% IN or OUT Phase

### Internal 8MHz GBWP Error Amplifier

- Includes bypass configuration to utilize external Error Amplifier

### Supports a wide 20kHz to 2MHz $f_{sw}$ range

- Option to synchronize to an external clock

### Choose between three options for OC response

- Cycle-by-Cycle Current Limit, Hiccup, Ignore

### Features synchronous rectification for improved efficiency

- Includes split deadtime control

### Low power startup current for offline power supplies

Flow	Part Number	TID LDR RLAT	SEE	Package
Rad Hard Hermetic	ISL73846SLHMF	75 krad(Si)	86 MeV·cm <sup>2</sup> /mg	24 Ld CFP
Rad Hard Plastic	ISL73846SLHMNEZ	75 krad(Si)	86 MeV·cm <sup>2</sup> /mg	64 Ld TQFP
Rad Tolerant Plastic	ISL73846M30/50NEZ	30/50 krad(Si)	46 MeV·cm <sup>2</sup> /mg	



## Push-Pull Converter Transient Response

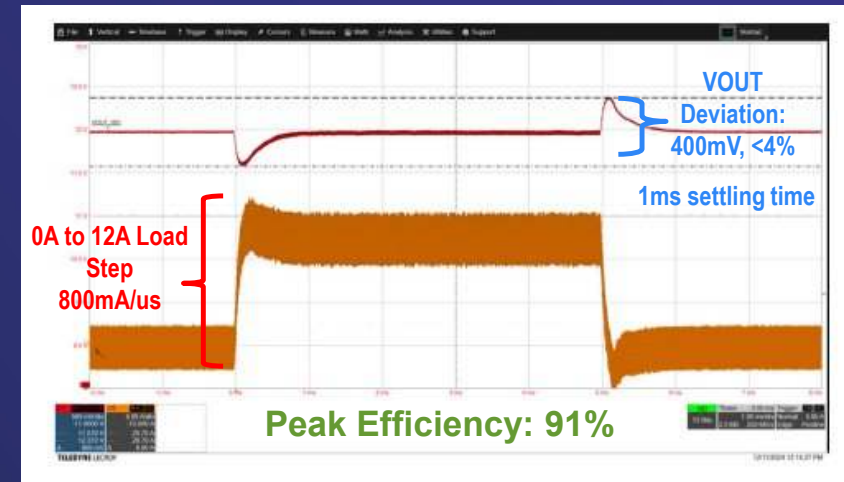

ISL73846MEV2Z  
Push Pull Reference Design  
28V to 12V, 144W



# ISL73846

## HIGHLY CONFIGURABLE FOR ISOLATED POWER

### Independent supplies and UVLO for chip & driver output stage

- Wide 4.5V to 20V range capable of driving MOSFETs or GaN FETs directly

### Select the control methodology

- Supports both current and voltage mode control

### Select the maximum duty cycle

- 50% Out of Phase or 100% IN or OUT Phase

### Internal 8MHz GBWP Error Amplifier

- Includes bypass configuration to utilize external Error Amplifier

### Supports a wide 20kHz to 2MHz $f_{sw}$ range

- Option to synchronize to an external clock

### Choose between three options for OC response

- Cycle-by-Cycle Current Limit, Hiccup, Ignore

### Features synchronous rectification for improved efficiency

- Includes split deadtime control

### Low power startup current for offline power supplies

Flow	Part Number	TID LDR RLAT	SEE	Package
Rad Hard Hermetic	ISL73846SLHMF	75 krad(Si)	86 MeV·cm <sup>2</sup> /mg	24 Ld CFP
Rad Hard Plastic	ISL73846SLHMNEZ	75 krad(Si)	86 MeV·cm <sup>2</sup> /mg	64 Ld TQFP
Rad Tolerant Plastic	ISL73846M30/50NEZ	30/50 krad(Si)	46 MeV·cm <sup>2</sup> /mg	



## Forward Converter Transient Response

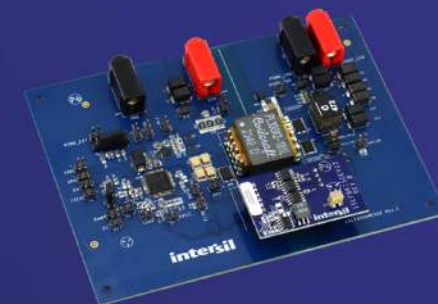
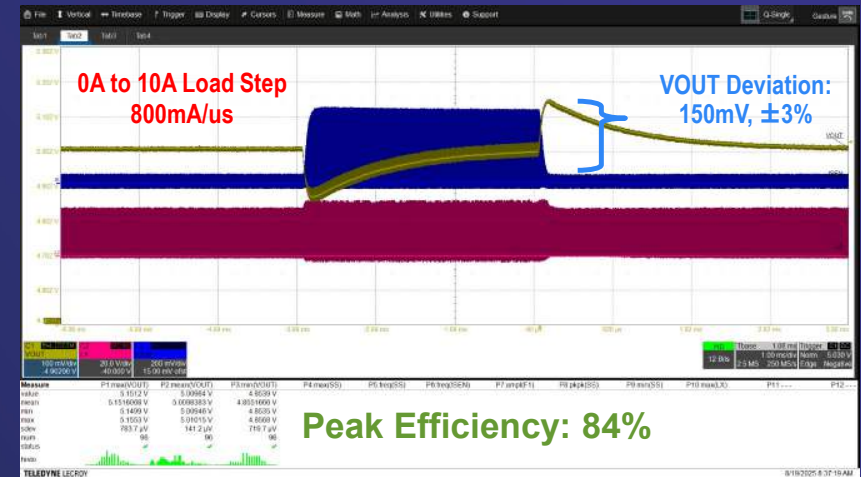

**ISL73846MEV2**  
Forward Reference Design  
28V to 5V, 50W



# ISL73846

## HIGHLY CONFIGURABLE FOR ISOLATED POWER

### Independent supplies and UVLO for chip & driver output stage

- Wide 4.5V to 20V range capable of driving MOSFETs or GaN FETs directly

### Select the control methodology

- Supports both current and voltage mode control

### Select the maximum duty cycle

- 50% Out of Phase or 100% IN or OUT Phase

### Internal 8MHz GBWP Error Amplifier

- Includes bypass configuration to utilize external Error Amplifier

### Supports a wide 20kHz to 2MHz $f_{sw}$ range

- Option to synchronize to an external clock

### Choose between three options for OC response

- Cycle-by-Cycle Current Limit, Hiccup, Ignore

### Features synchronous rectification for improved efficiency

- Includes split deadtime control

### Low power startup current for offline power supplies

Flow	Part Number	TID LDR RLAT	SEE	Package
Rad Hard Hermetic	ISL73846SLHMF	75 krad(Si)	86 MeV·cm <sup>2</sup> /mg	24 Ld CFP
Rad Hard Plastic	ISL73846SLHMNEZ	75 krad(Si)	86 MeV·cm <sup>2</sup> /mg	64 Ld TQFP
Rad Tolerant Plastic	ISL73846M30/50NEZ	30/50 krad(Si)	46 MeV·cm <sup>2</sup> /mg	



## 2-Phase Boost Converter Transient Response

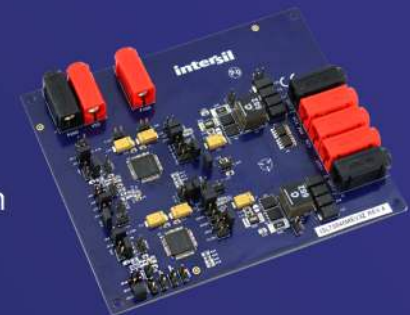
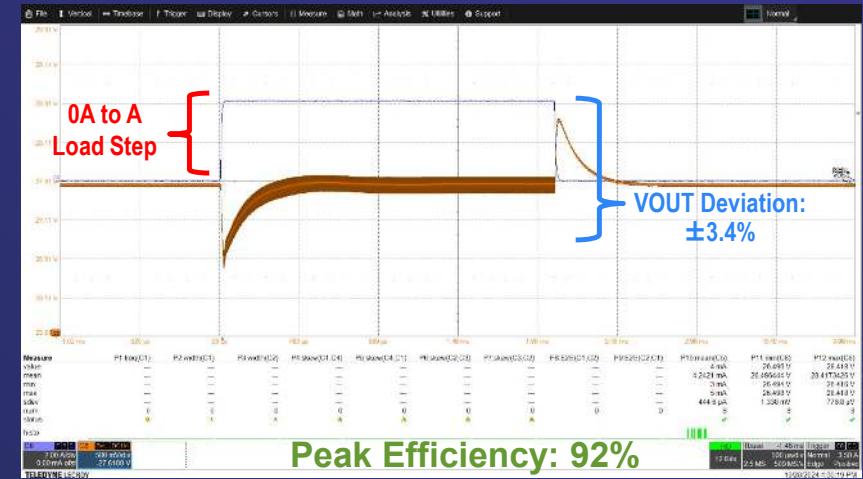

**ISL73846MEV3Z**  
2 Phase Boost Reference Design  
12V to 28V, 112W

# ISL75055

## MULTIPLE APPLICATIONS WITHOUT COMPROMISING PERFORMANCE



### First-of-Kind $\pm 3A$ LDO for both traditional LDO and DDR applications

- Single control loop for both source and sink operation
- Integrated  $\frac{1}{2}$  VDDQ VREF buffer for DDR applications
- 500mV voltage reference for traditional LDO applications

### 600 $\mu$ V Source/Sink Deadband

- Innovative architecture meets DDR requirements without sacrificing LDO performance

### VIN Range: 0.75V to 5.5V (3A VDO = 139mV)

- Split input and bias rails allows for reduced power dissipation at full load

### Configurable for individual application needs

- Configurable discharge FETs for VOUT and BUF-OUT
- Independent OCP control for sink/source
- Externally adjustable soft-start

### 1% DDR Accuracy, 1.5% LDO Accuracy

Flow	Part Number	TID LDR RLAT	SEE	Package
Rad Hard Hermetic	ISL75055SLHMF	75 krad(Si)	86 MeV $\cdot$ cm <sup>2</sup> /mg	18 Ld CFP
Rad Hard Plastic	ISL75055SLHMNEZ	75 krad(Si)	86 MeV $\cdot$ cm <sup>2</sup> /mg	48 Ld TQFP
Rad Tolerant Plastic	ISL75055M30/50NEZ	30/50 krad(Si)	46 MeV $\cdot$ cm <sup>2</sup> /mg	

### DDR Source/Sink Load Transient



# ISL75055

## MULTIPLE APPLICATIONS WITHOUT COMPROMISING PERFORMANCE



### First-of-Kind $\pm 3A$ LDO for both traditional LDO and DDR applications

- Single control loop for both source and sink operation
- Integrated  $\frac{1}{2}$  VDDQ VREF buffer for DDR applications
- 500mV voltage reference for traditional LDO applications

### 600 $\mu$ V Source/Sink Deadband

- Innovative architecture meets DDR requirements without sacrificing LDO performance

### VIN Range: 0.75V to 5.5V (3A VDO = 139mV)

- Split input and bias rails allows for reduced power dissipation at full load

### Configurable for individual application needs

- Configurable discharge FETs for VOUT and BUF-OUT
- Independent OCP control for sink/source
- Externally adjustable soft-start

### 1% DDR Accuracy, 1.5% LDO Accuracy

Flow	Part Number	TID LDR RLAT	SEE	Package
Rad Hard Hermetic	ISL75055SLHMF	75 krad(Si)	86 MeV $\cdot$ cm <sup>2</sup> /mg	18 Ld CFP
Rad Hard Plastic	ISL75055SLHMNEZ	75 krad(Si)	86 MeV $\cdot$ cm <sup>2</sup> /mg	48 Ld TQFP
Rad Tolerant Plastic	ISL75055M30/50NEZ	30/50 krad(Si)	46 MeV $\cdot$ cm <sup>2</sup> /mg	

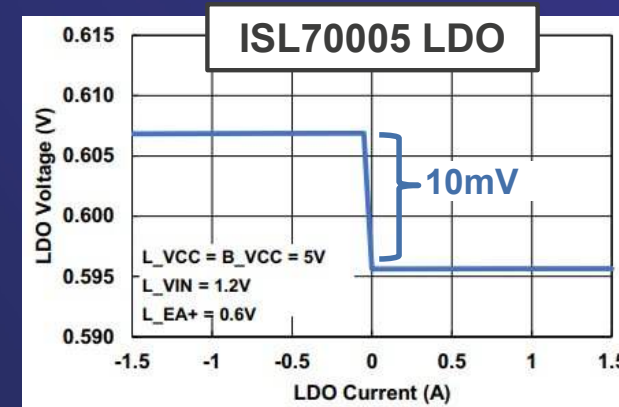
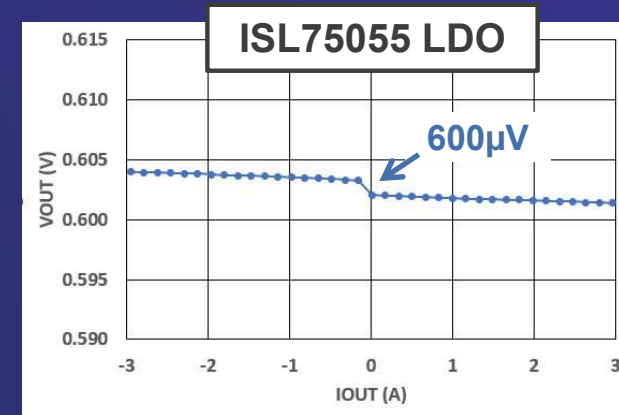

# ISL75055

## MULTIPLE APPLICATIONS WITHOUT COMPROMISING PERFORMANCE

### First-of-Kind $\pm 3A$ LDO for both traditional LDO and DDR applications

- Single control loop for both source and sink operation
- Integrated  $\frac{1}{2}$  VDDQ VREF buffer for DDR applications
- 500mV voltage reference for traditional LDO applications

### 600 $\mu$ V Source/Sink Deadband

- Innovative architecture meets DDR requirements without sacrificing LDO performance

### VIN Range: 0.75V to 5.5V (3A VDO = 139mV)

- Split input and bias rails allows for reduced power dissipation at full load

### Configurable for individual application needs

- Configurable discharge FETs for VOUT and BUF-OUT
- Independent OCP control for sink/source
- Externally adjustable soft-start

### 1% DDR Accuracy, 1.5% LDO Accuracy

Flow	Part Number	TID LDR RLAT	SEE	Package
Rad Hard Hermetic	ISL75055SLHMF	75 krad(Si)	86 MeV $\cdot$ cm <sup>2</sup> /mg	18 Ld CFP
Rad Hard Plastic	ISL75055SLHMNEZ	75 krad(Si)	86 MeV $\cdot$ cm <sup>2</sup> /mg	48 Ld TQFP
Rad Tolerant Plastic	ISL75055M30/50NEZ	30/50 krad(Si)	46 MeV $\cdot$ cm <sup>2</sup> /mg	



### DDR4 Applications

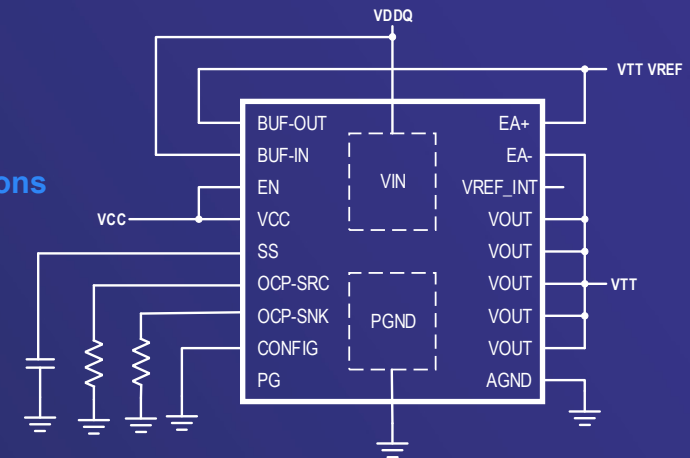

### Traditional LDO Applications

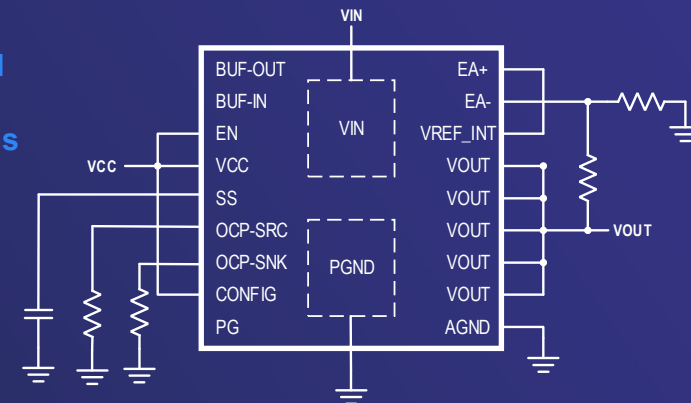

# ISL73849

## FLEXIBILITY THROUGH DIGITAL CONTROL AND TELEMETRY

### Single/Dual Phase Operation

- Well-suited for low voltage, high-current applications like ACAP/ FPGA or ASIC core voltages
- Features droop compensation for excellent transient response

### PMBus v1.3 Interface with Write Protection

- Built in write protection that (if enabled) requires 2 commands to modify protected registers
- Built on SEU immune logic cells

### Programmable VREF DAC Between 0.2V and 1.2V

- Change VOUT on the fly in as little as 8mV steps
- Configurable output slew rate

### Reconfigurable Fault Behavior and Masking

- Individually programmable OV & UV fault levels
- Individual fault responses and levels can be customized (hiccup, latch-off, masked)

Flow	Part Number	TID LDR RLAT	SEE	Package
Rad Hard Hermetic	ISL73849SLHMF	75 krad(Si)	86 MeV·cm <sup>2</sup> /mg	24 Ld CDFP
Rad Hard Plastic	ISL73849SLHMNZ	75 krad(Si)	86 MeV·cm <sup>2</sup> /mg	12 x 12 80 ld. ep TQFP
Rad Tolerant Plastic	ISL73849M30/50NEZ	30/50 krad(Si)	46 MeV·cm <sup>2</sup> /mg	

intersil™

### ISL73949 Efficiency

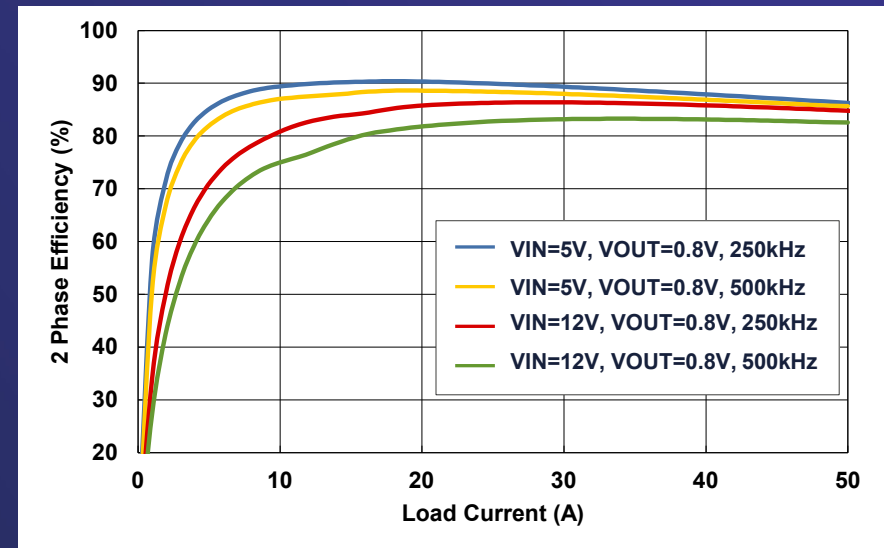

Add/remove phases to scale to any desired power level!

# ISL73849

## FLEXIBILITY THROUGH DIGITAL CONTROL AND TELEMETRY



### Single/Dual Phase Operation

- Well-suited for low voltage, high-current applications like ACAP/ FPGA or ASIC core voltages
- Features droop compensation for excellent transient response

### PMBus v1.3 Interface with Write Protection

- Built in write protection that (if enabled) requires 2 commands to modify protected registers
- Built on SEU immune logic cells

### Programmable VREF DAC Between 0.2V and 1.2V

- Change VOUT on the fly in as little as 8mV steps
- Configurable output slew rate

### Reconfigurable Fault Behavior and Masking

- Individually programmable OV & UV fault levels
- Individual fault responses and levels can be customized (hiccup, latch-off, masked)

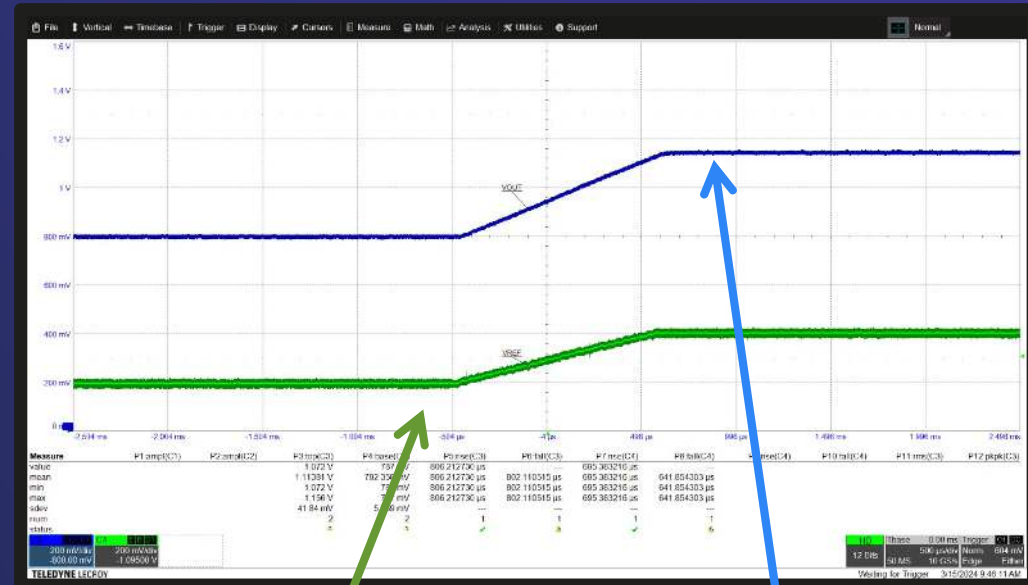

VREF digitally adjusted from 0.5V to 0.7V  
 VOUT transitions from 0.8V to 1.15V

Flow	Part Number	TID LDR RLAT	SEE	Package
Rad Hard Hermetic	ISL73849SLHMF	75 krad(Si)	86 MeV·cm <sup>2</sup> /mg	24 Ld CDFP
Rad Hard Plastic	ISL73849SLHMNZ	75 krad(Si)	86 MeV·cm <sup>2</sup> /mg	12 x 12 80
Rad Tolerant Plastic	ISL73849M30/50NEZ	30/50 krad(Si)	46 MeV·cm <sup>2</sup> /mg	ld. ep TQFP

# ISL73849

## FLEXIBILITY THROUGH DIGITAL CONTROL AND TELEMETRY



### Single/Dual Phase Operation

- Well-suited for low voltage, high-current applications like ACAP/ FPGA or ASIC core voltages
- Features droop compensation for excellent transient response

### PMBus v1.3 Interface with Write Protection

- Built in write protection that (if enabled) requires 2 commands to modify protected registers
- Built on SEU immune logic cells

### Programmable VREF DAC Between 0.2V and 1.2V

- Change VOUT on the fly in as little as 8mV steps
- Configurable output slew rate

### Reconfigurable Fault Behavior and Masking

- Individually programmable OV & UV fault levels
- Individual fault responses and levels can be customized (hiccup, latch-off, masked)

Hiccup  
OC1 Fault  
Response

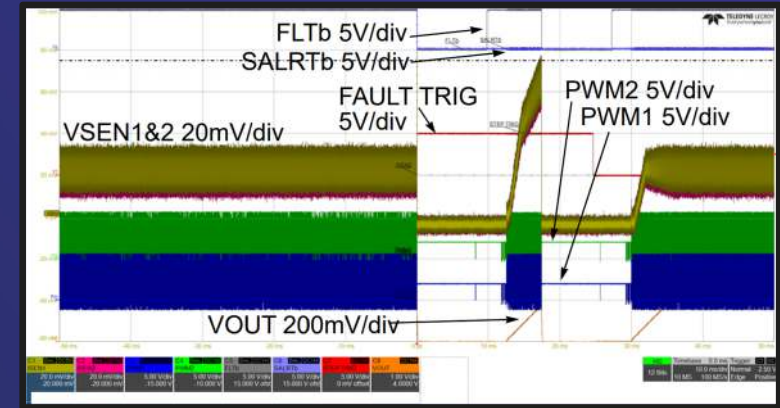

Latch-Off  
UV Fault  
Response

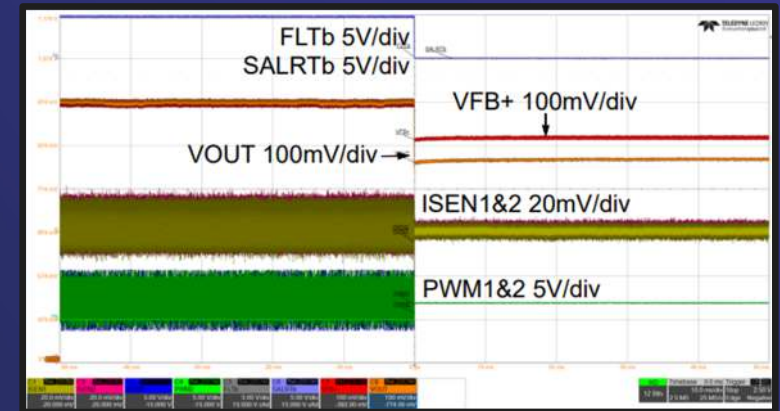

Flow	Part Number	TID LDR RLAT	SEE	Package
Rad Hard Hermetic	ISL73849SLHMF	75 krad(Si)	86 MeV·cm <sup>2</sup> /mg	24 Ld CDFP
Rad Hard Plastic	ISL73849SLHMNZ	75 krad(Si)	86 MeV·cm <sup>2</sup> /mg	12 x 12 80 ld. ep TQFP
Rad Tolerant Plastic	ISL73849M30/50NEZ	30/50 krad(Si)	46 MeV·cm <sup>2</sup> /mg	

# ISL73849

## FLEXIBILITY THROUGH DIGITAL CONTROL AND TELEMETRY



### Single/Dual Phase Operation

- Well-suited for low voltage, high-current applications like ACAP/ FPGA or ASIC core voltages
- Features droop compensation for excellent transient response

### PMBus v1.3 Interface with Write Protection

- Built in write protection that (if enabled) requires 2 commands to modify protected registers
- Built on SEU immune logic cells

### Programmable VREF DAC Between 0.2V and 1.2V

- Change VOUT on the fly in as little as 8mV steps
- Configurable output slew rate

### Reconfigurable Fault Behavior and Masking

- Individually programmable OV & UV fault levels
- Individual fault responses and levels can be customized (hiccup, latch-off, masked)

Flow	Part Number	TID LDR RLAT	SEE	Package
Rad Hard Hermetic	ISL73849SLHMF	75 krad(Si)	86 MeV·cm <sup>2</sup> /mg	24 Ld CDFP
Rad Hard Plastic	ISL73849SLHMNZ	75 krad(Si)	86 MeV·cm <sup>2</sup> /mg	12 x 12 80 ld. ep TQFP
Rad Tolerant Plastic	ISL73849M30/50NEZ	30/50 krad(Si)	46 MeV·cm <sup>2</sup> /mg	

Unmasked  
OC1 Fault  
Response

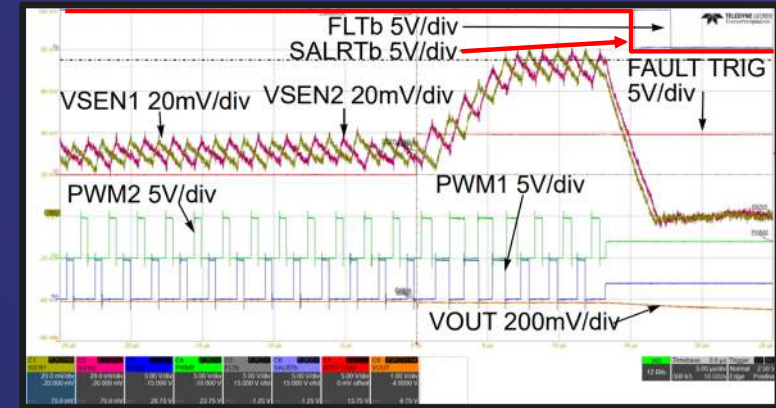

Masked  
UV Fault  
Response

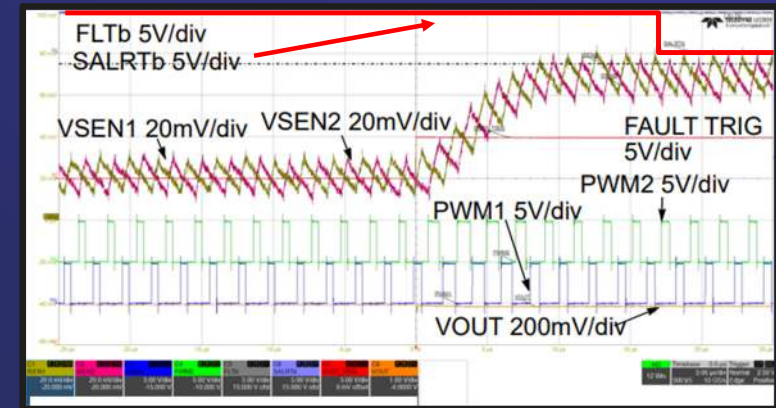

# CONCLUSION



Efficient



Reliable



Flexible

## ISL73846: Highly configurable for isolated power

20V double-ended PWM controller with synchronous rectification capable of supporting a wide array of power supply topologies

## ISL75055: Multiple applications without compromising performance

Source and sink LDO for both general purpose and DDR terminator applications

## ISL73849: Flexibility through digital control and telemetry

Single/dual phase PWM controller with PMBus and telemetry enabling dynamic control and opening a wide range of options

intersil™

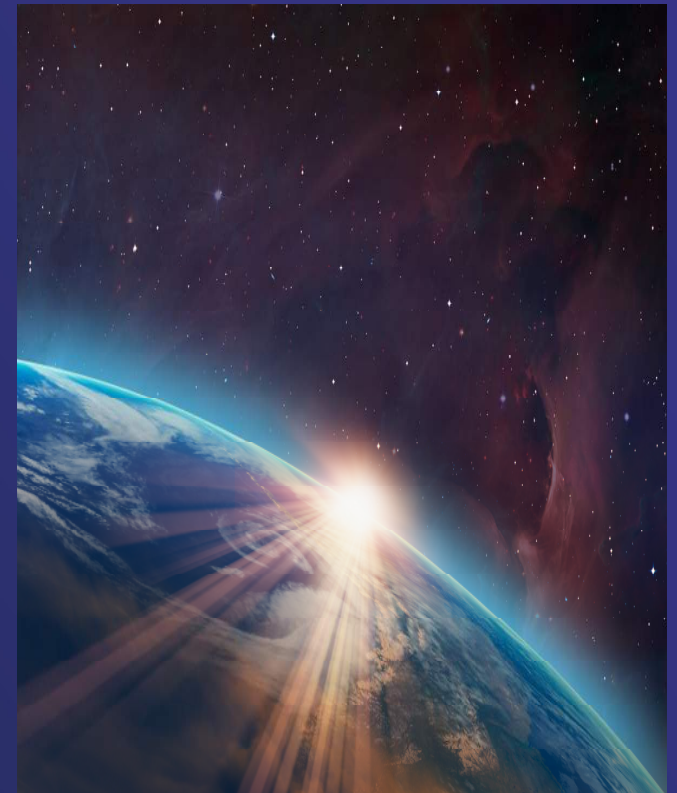



---

Thank you! Questions?

**Abigail Eberts**

**Strategic and Technical Product Marketing**

[abigail.eberts.uj@gr.renesas.com](mailto:abigail.eberts.uj@gr.renesas.com)